

SHANGHAI CIPHY INDUSTRY CO.,LTD.

ANSI CLASS 600/900

CARBON STEEL OR STAINLESS STEEL

GATE VALVE BOLTED BONNET DESIGN

OS&Y RISING STEM

MODEL NO: SAAXRF-RS



GATE VALVE PRODUCT'S SIZE:

PRESSURE GRADE	FROM	TO
CLASS 600	2"	12"

DESIGN DESCRIPTION:

- * **OUTSIDE SCREW AND YOKE;**
- * **BOLTED BONNET;**
- * **FLEXIBLE WEDGE, FULLY GUIDER;**
- * **INTEGRAL SEATS;**
- * **RISING STEM HANDWHEEL;**
- * **AVAILABLE WITH GEAR OPERATOR;**
- * **FLANGED ENDS OR BUTT-WELDING ENDS;**
- * **RISING FLANGE OR RING TYPE JOINT.**

WORKING TEMPERATURE:

WORKING TEMPERATURE		
MATERIAL	CELSIUR SCALE	FAHRENHEIT
CARBON STEEL	-290C~4250C	60F~8220F
STAINLESS STEEL	-400C~5500C	150F~10470F

GENERAL DESIGN SPECIFICATIONS:

ITEM	AMERICAN STANDARD	BRITISH STANDARD
MANUFACTURE	API 6D OR API 600	BS 1414
PRESSURE-TEMPERATURE RATINGS	ANSI B16.34	BS 1560
FACE TO FACE	ANSI B16.10	BS 2080
END TO END	ANSI B16.10	BS 2080
END FLANGE	ANSI B16.5	BS 1560
END BUTT-WELDING	ANSI B16.25	BS 1414
GASKET CONTACT	ANSI B16.5	BS 1560
INSPECTION AND TEST	API 598	BS 6755 PART 1

TEST PRESSURE TO API 598 OR BS 6755 PATRT 1

CLASS	SHELL (WATER)		SHELL (AIR)		SEAT (WATER)		SEAT (AIR)		BACK SEAT (WATER)	
600	15.3MPA	2225PSI	11.2MPA	1630PSI	11.2MPA	1630PSI	0.6MPA	80PSI	15.3MPA	2225PSI

TRIMS SPECITIED DUE TO TABLE 3:

DISC SEAT SURFACE PART NO.3	BODY SEAT SURFACE PART NO.2	STEM PART NO.4	BACKETSEAT PART NO.9
F6	F6	F6	F6
STELLITE	STELILITE	F6	F6
F6	STELILITE	F6	F6
304	304	F304	F304
316	316	F316	F316
304L	304L	F304L	F304L
316L	316L	F316L	F316L

OTHER MATERIALS ARE AVAILABLE UPON REQUEST.

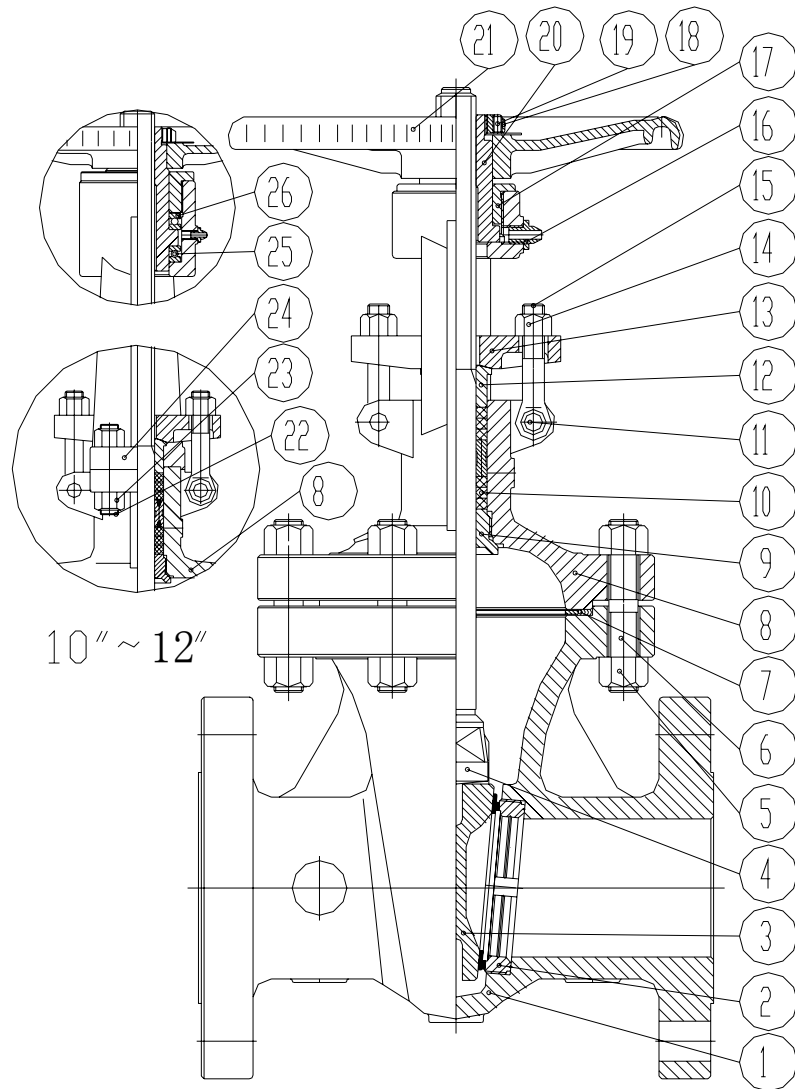

PARTS AND MATERIAL (ASTM)

NO	PARTS NAME	MATERIAL				
		A216-WCB	A351-CF8	A351-CF8M	A351-CF3	A351-CF3M
1	BODY	A216-WCB	A351-CF8	A351-CF8M	A351-CF3	A351-CF3M
5	BONNET BOLT NUT	A1942H	A1948	A1948	A1948	A1948
6	BONNET BOLT	A193B7	A193B8	A193B8	A193B8	A193B8
7	GASKET	REINFORCED FLAT GRAPHITE, OR SS SPIREAL WOUND W/GRAPHITE OR PTFE, OR REINFORCEPTFE				
8	BONNET	A216-WCB	A351-CF8	A351-CF8M	A351-CF3	A351-CF3M
10	STEM PACKING	BRAIDED GRAPITE OR DIEFORMED GRAPHITE RING OR PTFE				
11	EYE BOLT PIN	STEEL	ST. STEEL	ST. STEEL	ST. STEEL	ST. STEEL
12	GLAND	A182F6	SS304	SS316	SS304L	SS316L
13	GLAND FLANGE	A105	SS304	SS316	SS304L	SS316L
14	EYE BOLTED NUT	A1942H	A1948	A1948	A1948	A1948
15	EYE BOLT	A193B7	A193B8	A193B8	A193B8	A193B8
16	LUBRICATOR	STEEL				
17	RETAINER NUT	STEEL				
18	H.W.LOCK NUT	STEEL				
19	STOP BOLT	STEEL				
20	STEM NUT	A439-D2 OR A276-410				
21	HANDWHEEL	DUCTILE IRON				
22	YOKE BOLT	A193B7	A193B8	A193B8	A193B8	A193B8
23	YOKE BOLT NUT	A1942H	A1948	A1948	A1948	A1948
24	YOKE	A216-WCB	A351-CF8	A351-CF8M	A351-CF3	A351-CF3M
25	BOTTOM BEARING	STAINLESS STEEL				
26	UPPER BEARING	STAINLESS STEEL				

OTHER MATERIALS ARE AVAILABLE UPON REQUEST.

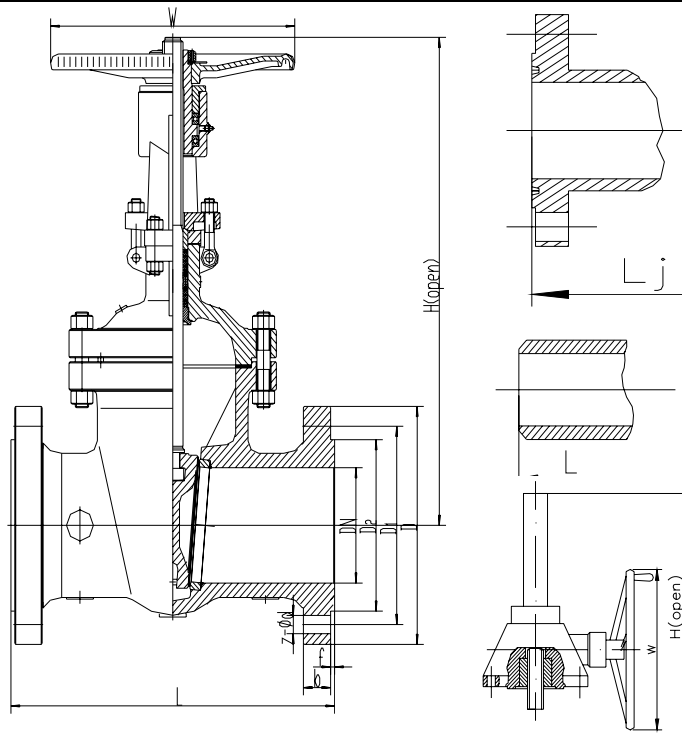

DIMENSIONS LIST (UNIT: MM):

CLASS 600 FLANGE END AND WELDING END

50	2	6.4	11-1/2	11-5/8	6-1/2	5	3-5/8	1	8*3/4	8	17	40
65	2-1/2	6.4	13	13-1/8	7-1/2	5-7/8	4-1/8	1-1/8	8*7/8	10	19-1/8	50
80	3	6.4	14	14-1/8	8-1/4	6-5/8	5	1-1/4	8*7/8	12	21-1/2	70
100	4	6.4	17	17-1/8	10-3/4	8-1/2	6-3/16	1-1/2	8*1	14	25-1/2	120
150	6	6.4	22	22-1/8	14	11-1/2	8-1/2	1-7/8	12*1-1/8	18	31-1/2	265
200	8	6.4	26	26-1/8	16-1/2	13-3/4	10-5/8	2-3/16	12*1-1/4	22	40-1/2	400
250	10	6.4	31	31-1/8	20	17	12-3/4	2-1/2	16*1-3/8	24	50	700
300	12	6.4	33	33-1/8	22	19-1/4	15	2-5/8	20*1-3/8	28	58-1/2	955

*** We hereby reserve the rights of any alternative dimension that would help to improve our valve's quality and working efficiency**



SHANGHAI CIPHY INDUSTRY CO.,LTD
7G-1 Building, N0.515 Yishan Rd.
Shanghai, China
TEL:+86-21-5497 5962
FAX:+86-21-5497 5963
HTTP://WWW.CIPHY.CN
CIPHY@CIPHY.COM
COPYRIGHT©2004-[CIPHY]
ALL RIGHTS RESERVED.